

# Eagle Pneumatic Ticket Delivery System



The Eagle Pneumatic Ticket Delivery System transports tickets 25 per second up to 1,000 feet through a single, connecting tube between the truck scale and the batchman/dispatch office. It can save between 3 and 5 hours of truck time for each 100 trucks that move through your yard.

The pneumatic dispatch system is a low-cost, easy-to-use system that helps move trucks through your operation faster than ever. This pressure/vacuum system is designed with a "recall" feature and stainless steel truck station for reliability and durability in any outside installation.

Ideal for rock quarries, asphalt and concrete plants, the Eagle Pneumatic Ticket Delivery System saves your operation time and money while you keep focused on your business moving forward. Call your Eagle Pneumatic dealer today.



# Eagle Pneumatic Ticket Delivery System

## Mini Ticket Delivery—Powered Station

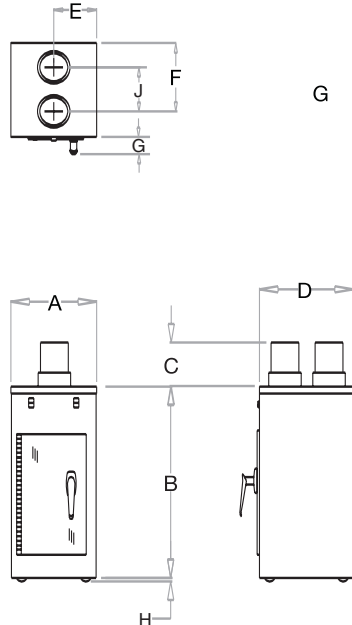

### DIMENSIONS

| System Size | 3"      | 4"      |
|-------------|---------|---------|
| <b>A</b>    | 9 1/4"  | 9 1/4"  |
| <b>B</b>    | 20 5/8" | 20 5/8" |
| <b>C</b>    | 4 3/4"  | 4 3/4"  |
| <b>D</b>    | 10 1/8" | 10 1/8" |
| <b>E</b>    | 4 5/8"  | 4 5/8"  |
| <b>F</b>    | 6 7/8"  | 7 1/4"  |
| <b>G</b>    | 1 7/8"  | 1 7/8"  |
| <b>H</b>    | 3/4"    | 3/4"    |
| <b>J</b>    | 4 1/4"  | 4 3/4"  |

### ELECTRICAL REQUIREMENTS

**Power, all models:** 115V, single-phase, 60 Hz

## Stainless Steel Truck Station—Non-Powered

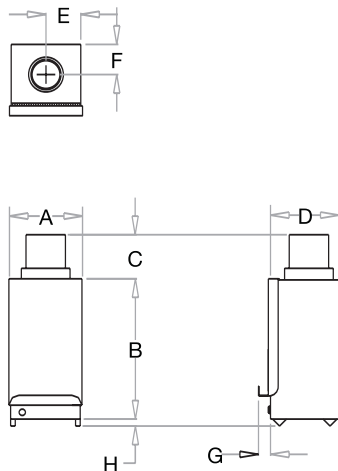

### DIMENSIONS

| System Size | 3"      | 4"      |
|-------------|---------|---------|
| <b>A</b>    | 7 7/8"  | 7 7/8"  |
| <b>B</b>    | 15 1/8" | 15 1/8" |
| <b>C</b>    | 4 3/4"  | 4 3/4"  |
| <b>D</b>    | 8"      | 8"      |
| <b>E</b>    | 4"      | 4"      |
| <b>F</b>    | 3 1/2"  | 3 3/8"  |
| <b>G</b>    | 1 1/8"  | 1 1/8"  |
| <b>H</b>    | 3/4"    | 3/4"    |

### DOWN SEND STATIONS AVAILABLE

\* Requires control cable between stations.



**Eagle Pneumatic, Inc.**  
 3902 Industry Boulevard  
 Lakeland, Florida 33811  
 Tel: 863.644.4870  
 Tel: 800.237.8261  
 Fax: 863.647.5328

E-mail: [sales@eaglepneumatic.com](mailto:sales@eaglepneumatic.com)  
[www.eaglepneumatic.com](http://www.eaglepneumatic.com)